

# T125 Fig. 5



## Standard Features

- ◆ Welded Steel Frame
- ◆ Belt Drive
- ◆ Separate Motor/Gear Reducer
- ◆ Machined Surfaces
- ◆ Strong, Reliable Bearings
- ◆ Machined-Pressed Fit Collector
- ◆ Rack and Pinion/machined Mounting Plates

## T125 Fig. 5

700 LB Load Capacity

The T125 Fig. 5 is the Smallest of our "T" Series rotators. Our "T" Series rotators use a separate motor and worm gear reducer along with a belt drive system to provide high torque, long life, and easy serviceability.

The motor and reducer are mounted on mounting plates that include a rack and pinion adjustment system along with machined tracks that allow quick and easy belt adjustment or replacement in a matter of minutes. There is no need to disassemble the rotator to make adjustments or changes so you save time on maintenance compared to other rotators.

### Optional Features:

- ◆ Rotation speeds from 1/2 to 10 RPM
- ◆ 0 to 8 Collector ring capacity

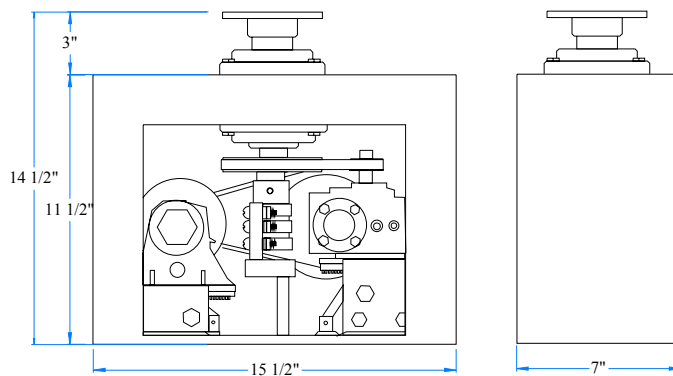

Dimensions shown are for rotator with 0 to 5, 30A collector rings. Add 3/4" to overall height for each additional collector ring

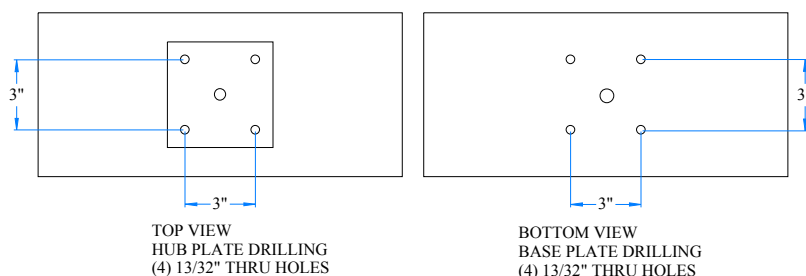

TOP VIEW  
HUB PLATE DRILLING  
(4) 13/32" THRU HOLES

BOTTOM VIEW  
BASE PLATE DRILLING  
(4) 13/32" THRU HOLES

## Larsen Manufacturing Company

Tel: 866-699-5918

Fax: 801-876-2115

email: sales@semcomotion.com

[www.semcomotion.com](http://www.semcomotion.com)

